

# Global Energy Management System Implementation: Case Study

South Korea

## LG Display Paju Plant

LG Display's Paju plant saved 1,180,412 GJ of energy per year in 2016



LG Display's Paju Plant was recognized as an excellent workplace for the energy management system of Korea Energy Corporation in 2017 by continuous energy management and innovation activities.

### Business Case for Energy Management

Organization overview and business case

Based on technologies such as organic light emitting diode (OLED), wide viewing angle (IPS), and flexible, LG Display produces and sells a variety of displays and related products ranging from TVs, Based on its technological strength and ongoing challenges, it has achieved the top position in the global large-size display market for 7 consecutive years from 2010 and is leading the national economy and industrial development.

LG Display acquired the ISO50001 certification for the energy management system in 2013, and manages the various existing business processes in conjunction with the energy management system, and systematically analyzed energy usage and operation time in real time by area / usage.

We have established company-wide energy management policies and reorganized related internal standard processes. We are also conducting energy

*"We will contribute to national economy and industrial development through continuous energy saving."*

-Sang-Beom Han, CEO and Vice Chairman of LG Display

### Case Study Snapshot

<b>Industry</b>	LCD flat panel display manufacturing industry
<b>Product/Service</b>	TV, Monitor, Laptop, Mobile Display Panels
<b>Location</b>	Paju, Gyeonggi, Korea
<b>Energy Management System</b>	ISO 50001
<b>Energy Performance Improvement Period</b>	1year (2016)
<b>Energy Performance Improvement (%) over improvement period</b>	3.2% (Baseline 2015)
<b>Total energy cost savings over improvement period</b>	11,768,567 USD
<b>Cost to implement EnMS</b>	4,382,148 USD
<b>Payback period (years) on EnMS implementation</b>	0.37year
<b>Total Energy Savings over improvement period</b>	1,180,412 (GJ)
<b>Total CO<sub>2</sub>-e emission reduction over improvement period</b>	169,511 (Ton)

- management training for the employees in charge of each department. In the future, it plans to promote the stabilization of the energy management system, operation improvement, and the indexing of the performance to enhance the implementation of energy saving.

**Business Benefits Achieved**

LG Display has formed the Energy Management Committee, which is chaired by the Director of Production Technology Center, and the E-saving TDR, which is a company-wide energy saving organization, to create an enterprise-wide energy management culture that encompasses domestic and overseas subsidiaries in Paju and Gumi. Each plant's annual goal setting reflects the Energy Saving Index, sets the energy usage target to the lower team, and periodically analyzes and shares energy use by organization on a daily and monthly basis. We are encouraging people to practice energy conservation.

In 2014, we standardize in-house lighting to suit the workplace environment, and we carry out energy conservation throughout the company by automating the flashing of in-house lights using IoT (Internet of Things). From 2012 to 2016, we promoted the replacement of low-power, high-efficiency dry process vacuum pumps, installation of cold water production system using outside-cold heat, and introduction of considerable energy-saving equipment such as humidification of air conditioners.

This achievement is a result of the energy management system performance evaluation by the Korea Energy Corporation as a reliable figure that has been verified by a third party.

- Baseline period : 2015
- Project period : 2016
- Energy result (Electricity) : 3.0 % (1,060,422 GJ)
- Energy result (Thermal Energy) : 14.6 % (119,990 GJ)
- Energy result (total) : 3.2 % (1,180,412 GJ)
- Energy reducing cost : 11,768,567 USD /year

**EnMS Development and Implementation**

**Organization**

LG Display operates the energy management system organization with our head office as the mainstay in order to promote enterprise-wide energy management. In Paju business, we are promoting the following roles and activities

Table. Energy Management Organization Roles and Activities

Organization	Roles and Activities
Paju Electricity team	<ul style="list-style-type: none"> <li>• Energy usage analysis, forecasting and management, energy budget management</li> <li>• Establishment and progress of corporate power saving award standard</li> <li>• PEMS System Management and ISO 50001 Certification / Management</li> <li>• Promotion of energy management system</li> </ul>
E-Saving TDR	<ul style="list-style-type: none"> <li>• Issue of power consumption daily report and construction of reporting system</li> <li>• Establish reduction goals and allocation criteria</li> <li>• Saving between Organizations Item Ride Development Guide</li> <li>• Operate periodic meetings to reduce power consumption</li> </ul>

**Energy review and planning**

The LG Display Paju plant is equipped with the latest Fence Diagram to update the process flow, facility expansion and dismantling frequently due to the remarkable level of technological innovation, and to enable the energy management team to grasp the energy flow every year and is managed by updating the version.

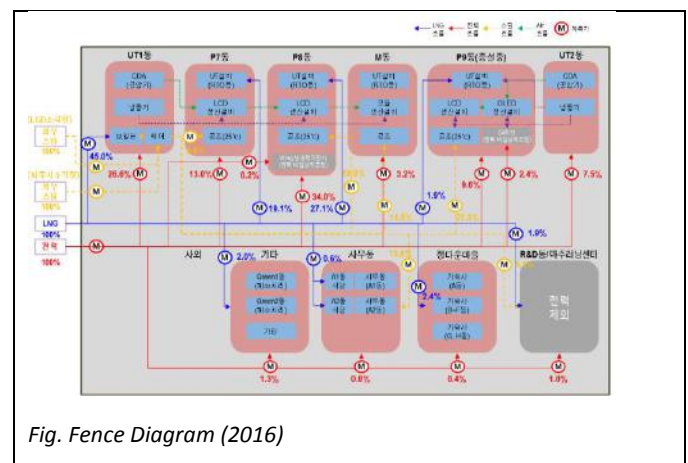

Fig. Fence Diagram (2016)

**Significant Energy Use (SEU) Drawing**

To ensure the energy management and savings opportunities deriving critical control target SEU has always managed.

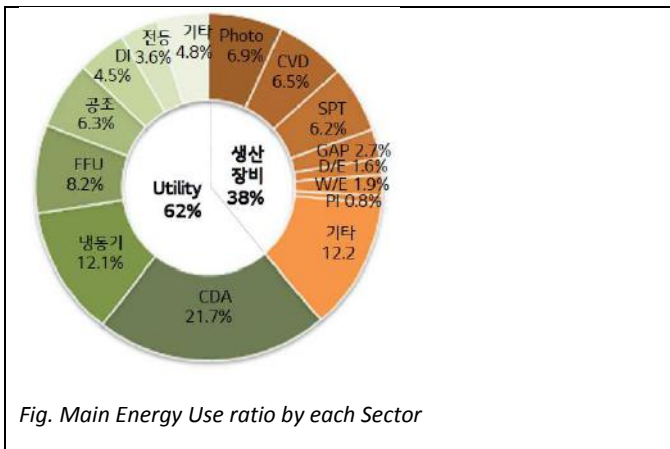

Fig. Main Energy Use ratio by each Sector

The use ratio of production equipment and utility facilities is about 4: 6. Compressor for production of compressed air (CDA) and clean room, and refrigerator for maintaining office temperature account for 33.8% of total, and SEU centered on energy saving activities have.

**Finding opportunities for improvement**

The Paju plant is one of the most energy-intensive businesses in the domestic manufacturing industry that uses more than 900,000 TOE per year of energy. We are continuously striving to become the world's top smart energy factory by challenging the limits of energy saving every time.

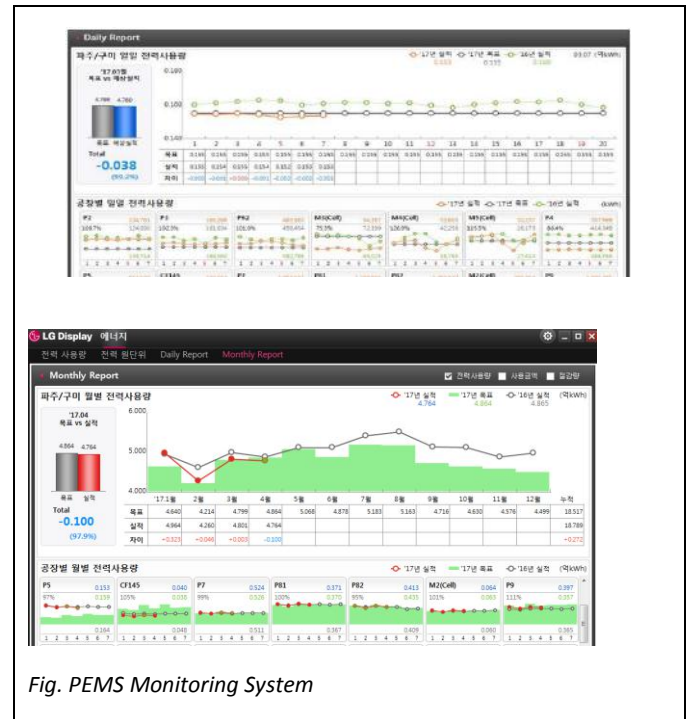

Fig. PEMS Monitoring System

Real-time monitoring of energy use by each process, analysis of the predicted quantity, and analysis of the performance, are reviewed for opportunities to save energy.

As part of this effort, we have applied Factory Energy Control, Management and Operation System (FEMS) to the Paju Plant to optimize the use and management of energy needed for product production. In May 2017, we established Factory Energy Management System (FEMS) in the installation confirmation system, a total of 11 items were evaluated and received the highest score of 90 or more.

In particular, we built and operated a PEMS (Plant Environment Management System), a real-time monitoring system that allows us to grasp the production, transportation, and usage of all energy in the plant at a glance received.

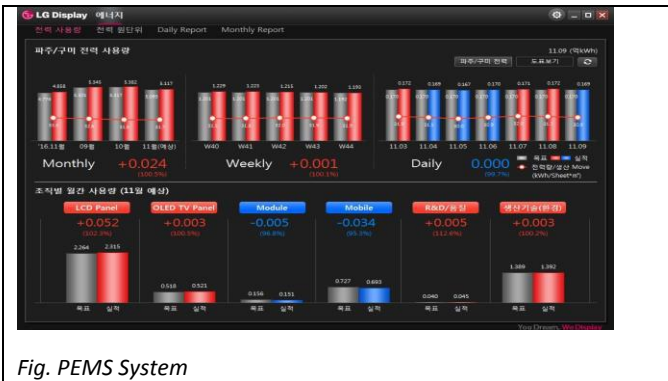
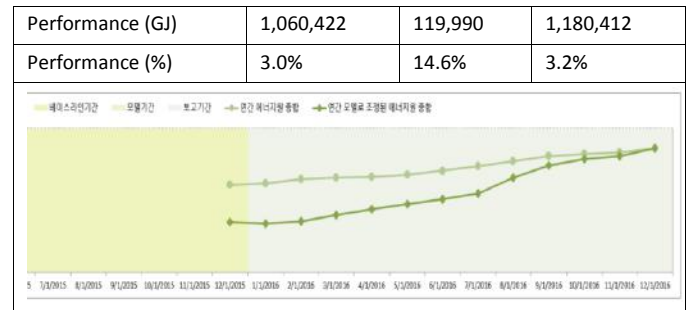

Fig. PEMS System



In order to carry out these achievements continuously and analyze it, we are establishing departmental performance indicators from the enterprise level and strengthening the execution ability of the energy management system of the production department.

### Cost Benefit

In addition to air conditioning and utility facilities and lighting, company-wide energy conservation campaigns have encouraged all employees to participate in energy conservation. Energy management projects have significantly reduced energy costs.

### Identifying of Influential factors

EnPI for energy saving activities and performance analysis of the workplace is derived and used for energy use prediction and performance analysis. Considering the energy use characteristics of the production facilities and utility facilities, factors affecting the increase and decrease of energy use respectively.

Table. Impact factor drawing

Energy source	Independent Variable (P-Value)				F-Test	R <sup>2</sup>
	Production Area (m <sup>3</sup> )	Glass Input (EA)	HDD (25°C)	CDD (25°C)		
Electricity (GJ)	0.00011			0.00084	0.00	89.14% (Adj)
Heat(GJ)			0.00000		0.00	94.03%

### Energy performance drawing

The energy performance of 2016 compared to 2015 was confirmed through the performance analysis using the linear regression model between the influence factor and the energy consumption. As a result, the energy performance of 3.2% was confirmed.

Table. Energy Performance

Division	Year	Electricity (GJ)	스팀(GJ)	Total (GJ)
Baseline Period	2015	35,920,036	824,763	36,744,798
Reporting Period	2016	34,859,614	704,772	35,564,386

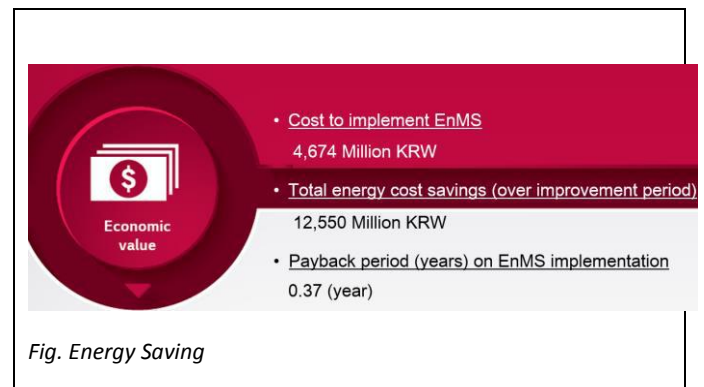

Fig. Energy Saving

### Communication, Education and Tool

We are developing sustainability management reports to communicate with stakeholders both internal and external to energy management activities and economic, environmental and social performance.

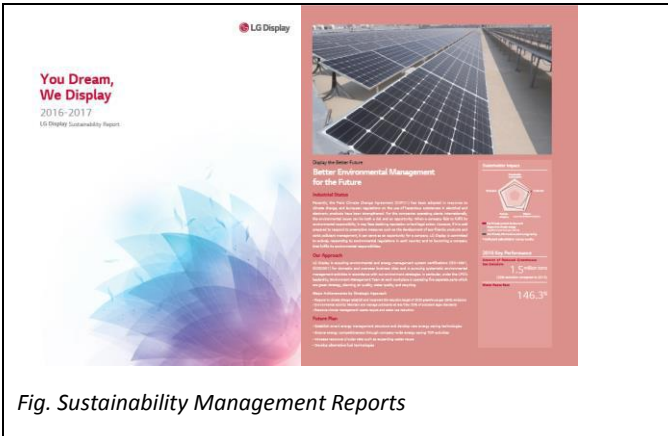

Fig. Sustainability Management Reports

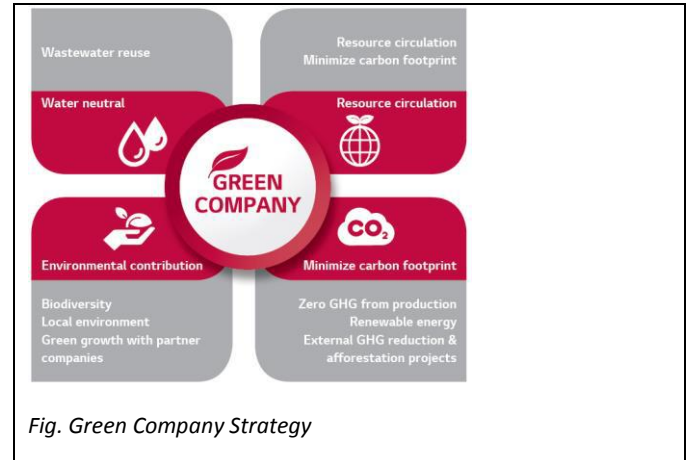

Fig. Green Company Strategy

LG Display acquired 'Leadership A', the highest level of water management, at the '2016 CDP Water Best Awards' selected by the CDP (Cabin Disclosure Project) committee. LG Display is actively engaged in global activities to counter global risks.

Lessons Learned

Leading the growth of Large Enterprise and SMEs

It is also important to share and impart know-how on LG Display's energy management system as much as the effort to build and operate the world's top-level Smart Energy Factory.



Fig. '2016 CDP Water Best Awards'



Fig. Celebration of joint growth

We are fulfilling our corporate social responsibilities through environmentally friendly management at the global level. In order to solve the global problem of resource depletion and abnormal climate problem, we have established green corporate strategy to preemptively respond to climate problems through activities such as resource circulation and greenhouse gas reduction.

LG Display operates green SCM consulting and carbon partnership to spread environmental preservation activities to partner companies and support green growth projects. Through Green CSM consulting, we provide greenhouse gas inventory and energy diagnosis to our partners to support suppliers' greenhouse gas regulations. We are also pursuing joint green growth by providing additional incentives for regular follow-up management and procurement for partners who have successfully implemented Green SCM consulting. Since 2013, we have been monitoring and providing technical support for environmental management in order to

strengthen our suppliers' ability to comply with environmental regulations.

## Presidential Award for Korea Energy Efficiency Award



Fig. Presidential Award for Korea Energy Efficiency Award

In recognition of its energy management activities and sustained energy savings, LG Display won the Presidential Recognition Award for Korea Energy Efficiency Award in 2017, I will do my best to contribute to industrial development.

## Keys to Success

- Establishment of smart energy management system and development of new energy saving technology
- Ensure energy competitiveness through company-wide energy saving TDR activities
- Development of alternative fuel technology

Through the Energy Management Working Group (EMWG), government officials worldwide share best practices and leverage their collective knowledge and experience to create high-impact national programs that accelerate the use of energy management systems in industry and commercial buildings. The EMWG was launched in 2010 by the Clean Energy Ministerial (CEM) and International Partnership for Energy Efficiency Cooperation (IPEEC).

For more information, please visit [www.cleanenergyministerial.org/energymanagement](http://www.cleanenergyministerial.org/energymanagement).

